



# Humidity & Temperature Transmitter E2218



## Features

- Excellent repeatability and stability
- Fully calibrated and temperature compensated
- Heavy duty IP65 protected enclosure
- 0-10 V or 4-20 mA switchable analog outputs
- RS485 Modbus RTU digital interface
- Attached or remote probe

## Specifications

Sensor	Digital combined RH and T sensor
Measurement range	0...100 %RH, -40...+85 °C or -40...+125 °C
Calculated parameters:	Dew point, absolute humidity
Resolution	0,1 %RH / 0,1 °C
Accuracy	±2,5 %RH / ±0,3 °C ±1,8 % RH / ±0,3 °C on request
Response time	~15 seconds
Self-diagnostics	Full functionality check at start-up
Warm-up time	≤ 1 s
Power supply	11...30 VDC, nominal 24 VDC or 24 VAC ±10%
Power consumption	< 1,5 VA
Digital interface	RS485, Modbus RTU protocol
Analog outputs	2 × 4-20 mA / 0-10 V, user settable, freely configurable scales
Fieldbus interface	RS485, Modbus RTU protocol
Cable connections	Screwless terminal blocks
Probe connector	Round industrial M12, IP68
Enclosure	Grey ABS, wall mount, protection class IP65
Dimensions	H82 × W80 × D55 mm
Operating environment	industrial indoor and outdoor places
Operating conditions	-40...+85 °C, 0...100 %RH
Standard probe HT-RP16	Ø16×L90 mm, M12 plug, -40...+85 °C
Probe extension cables	RPEC-2: PVC, length 2,5 m RPEC-5: PVC, length 5,0 m
Micro probe HT-RP04	st. steel Ø4×L50 mm, -40...+85 °C, attached PVC cable 2 m or 5 m
Heavy duty probe HT-RP16H	Ø16×L90 mm, -40...+125 °C, attached PTFE cable 2 m or 5 m, M12 plug

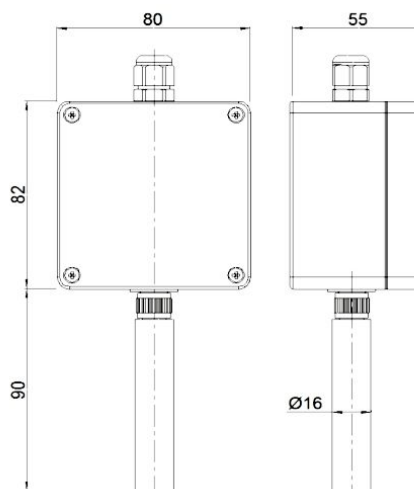

Sensor probe HT-RP16

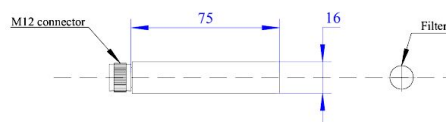

Sensor probe HT-RP04



Sensor probe HT-RP16-H

