

Characterised control valve, 2-way,  
Flange, PN 16

- For closed cold and warm water systems
- For water-side modulating control of air-handling and heating systems
- Air bubble tight

**Type overview**

Type	DN [ ]	DN ["]	kvs [ m <sup>3</sup> /h]	PN [ ]	Sv min. [ ]
<b>R6065W63-S8</b>	65	2 1/2	63	16	100
<b>R6080W100-S8</b>	80	3	100	16	100
<b>R6100W160-S8</b>	100	4	160	16	100
<b>R6125W250-S8</b>	125	5	250	16	100
<b>R6150W320-S8</b>	150	6	320	16	100

**Technical data**

<b>Functional data</b>	Media	Cold and warm water, water with glycol up to max. 50% vol.
	Medium temperature	-10...120°C
	Permissible pressure ps	1600 kPa
	Closing pressure Δps	690 kPa
	Differential pressure Δpmax	400 kPa
	Flow characteristic	Equal percentage (VDI/VDE 2178), optimised in the opening range
	Leakage rate	Leakage rate A, air-bubble-tight (EN 12266-1)
	Pipe connectors	Flange PN 16 according to EN 1092-2
	Angle of rotation	90° (Operating range 15...90°)
	Installation position	Upright to horizontal (in relation to the stem)
	Maintenance	Maintenance-free
<b>Materials</b>	Housing	EN-JL1040 (GG25), with protective paint
	Closing element	Stainless steel AISI 316
	Stem	Stainless steel AISI 304
	Stem seal	EPDM Perox
	Valve seat	PTFE
	Characterising disc	Stainless steel

**Safety notes**

- The valve has been designed for use in stationary heating, ventilation and air-conditioning systems and is not allowed to be used outside the specified field of application, especially in aircraft or in any other airborne means of transport.
- Only authorised specialists may carry out installation. All applicable legal or institutional installation regulations must be complied during installation.
- The valve does not contain any parts that can be replaced or repaired by the user.
- The valve may not be disposed of as household refuse. All locally valid regulations and requirements must be observed.
- When determining the flow rate characteristic of controlled devices, the recognised directives must be observed.

## Product features

- Mode of operation** The characterised control valve is adjusted by a rotary actuator. The actuator is controlled by a commercially available modulating or 3-point control system and moves the ball of the valve – the throttling device – to the position dictated by the positioning signal. Open the characterised control valve counterclockwise and close it clockwise.
- Flow characteristic** Equal percentage flow control is ensured by the integrated characterising disc.

## Accessories

	Description	Type
Electrical accessories	Stem heating flange ISO 5211, F05 (30W)	ZR24-F05

## Installation notes

- Recommended installation positions** The ball valve can be installed upright to horizontal. The ball valve may not be installed in a hanging position, i.e. with the stem pointing downwards.

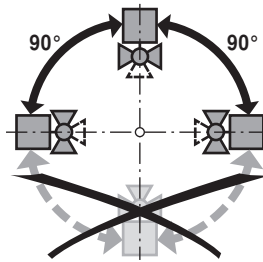

- Water quality requirements** The water quality requirements specified in VDI 2035 must be adhered to. Belimo valves are regulating devices. For the valves to function correctly in the long term, they must be kept free from particle debris (e.g. welding beads during installation work). The installation of suitable strainer is recommended.
- Stem heating** In cold water applications and warm humid ambient air can cause condensation in the actuators. This can lead to corrosion in the gear box of the actuator and causes a breakdown of it. In such applications, the use of a stem heating is provided. The stem heating must be enabled only when the system is in operation, because it does not have temperature control.
- Maintenance** Ball valves and rotary actuators are maintenance-free. Before any kind of service work is carried out on the actuator, it is essential to isolate the rotary actuator from the power supply (by unplugging the electrical cable). Any pumps in the part of the piping system concerned must also be switched off and the appropriate slide valves closed (allow everything to cool down first if necessary and reduce the system pressure to ambient pressure level). The system must not be returned to service until the ball valve and the rotary actuator have been properly reassembled in accordance with the instructions and the pipeline has been refilled in the proper manner.

### Installation notes

**Flow direction** The direction of flow, specified by an arrow on the housing, is to be complied with, since otherwise the ball valve could become damaged. Please ensure that the ball is in the correct position (marking on the spindle).

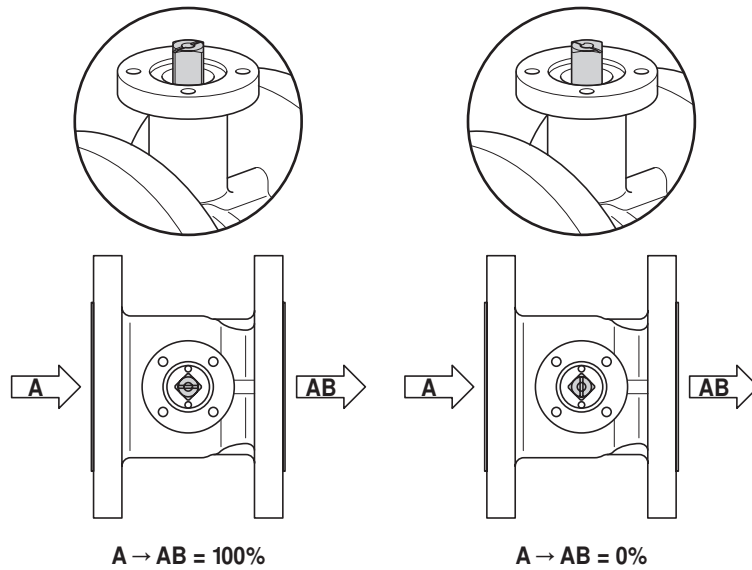

### Dimensions / Weight

#### Dimensional drawings

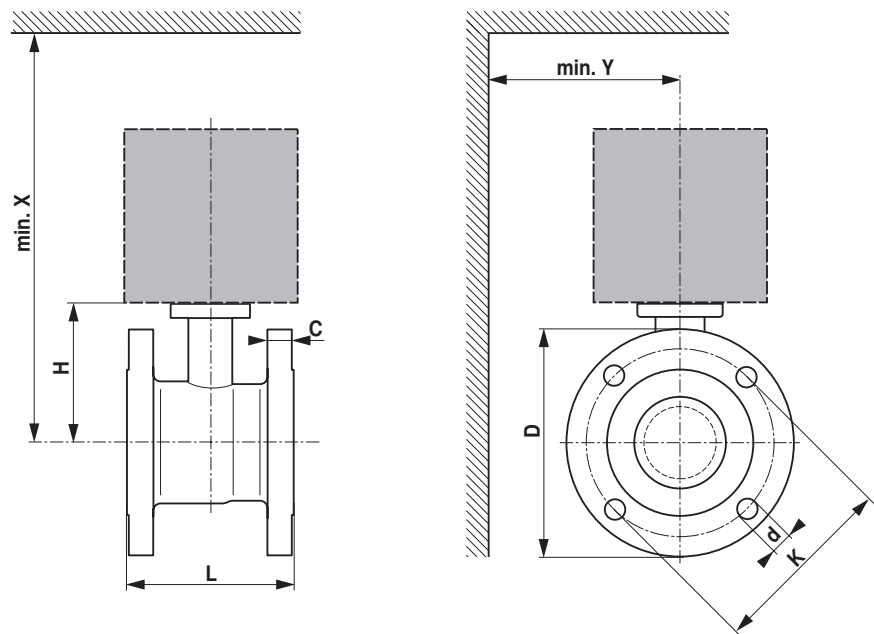

X/Y: Minimum distance with respect to the valve centre.  
The actuator dimensions can be found on the respective actuator data sheet.

Type	DN [ ]	L [ mm]	H [ mm]	C [ mm]	D [ mm]	d [ mm]	K [ mm]	X [ mm]	Y [ mm]	Weight approx. [ kg]
R6065W63-S8	65	136.5	113	18.5	185	4 x 19	145	320	150	12
R6080W100-S8	80	168	113	20.5	200	8 x 19	160	320	160	15
R6100W160-S8	100	211	124	22	224	8 x 19	180	330	175	24
R6125W250-S8	125	262.5	143	22	252	8 x 19	210	350	190	32
R6150W320-S8	150	315	143	22	282	8 x 23	240	350	200	41

**Further documentation**

- Overview Valve-actuator combinations
- Data sheets for actuators
- Installation instructions for actuators and/or ball valves
- General notes for project planning

71078-00001.B

