

F74C/FN74C

Reverse rinsing fine filter

Product specification sheet

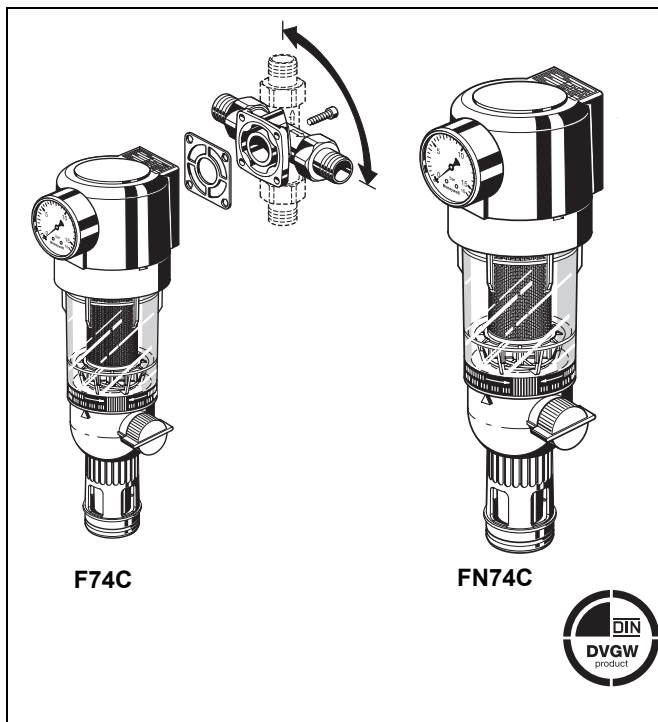

Construction

The fine filter comprises:

- Housing with pressure gauge
- Threaded connections
- Rotatable connector piece (F74C only)
- Fine filter in clear filter bowl
- Ball valve with drain connection
- Double wing wrench

Materials

- High quality synthetic material housing
- Brass threaded connections
- Red bronze connector piece (F74C only)
- Stainless steel fine filter
- Shock-resistant, clear transparent synthetic material filter bowl
- NBR seals

Application

F74C/FN74C reverse rinsing filters ensure a continuous supply of filtered water. The fine filter prevents the ingress of foreign bodies, for example rust particles, strands of hemp and grains of sand. F74C/FN74C fine filters are used in systems where an existing pressure reducing valve is fitted or where one is not required. Both horizontal and vertical installation is possible.

Special Features

- DIN/DVGW approved
- Filtered water supplied even during reverse rinsing
- Patented reverse rinsing system - fast and thorough cleaning of the filter with small amount of water
- Memory ring indicates when next manual reverse rinsing is due
- Automatic reverse rinsing actuator with bayonet connector can be retrofitted
- Large filter surface
- Shock resistant clear synthetic material filter bowl enables easy checking of filter contamination
- Filter and complete filter bowl are replaceable
- Very simple operation
- Standardised discharge connection
- Meets KTW recommendations for potable water

Range of Application

Medium Water

The filter is constructed for drinking water installations. In case of a process water application the filter has to be proven individually.

Technical Data

Installation position	Vertical or horizontal, with filter bowl downwards
Operating pressure	Minimum 1.5 bar Maximum 16.0 bar
Operating temperature	Maximum 30 °C
Connection size	3/4", 1", 1 1/4"

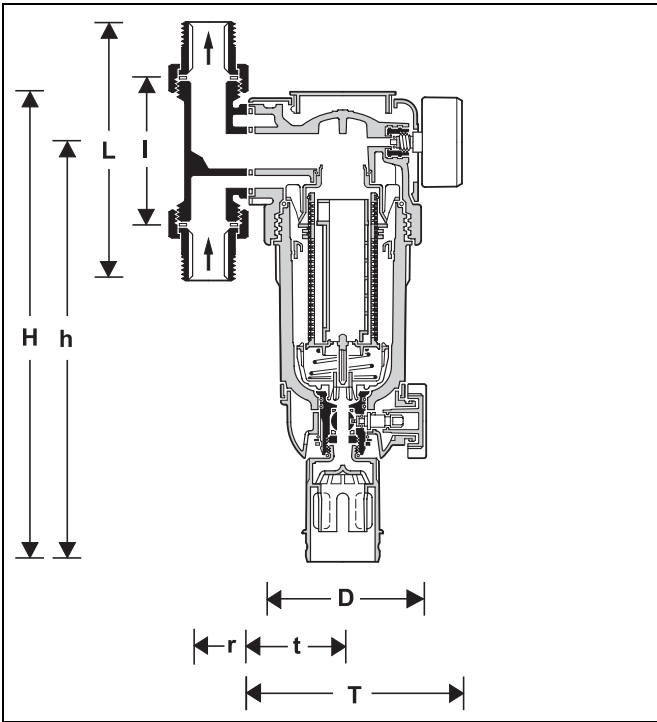

Connection size DA74C	R	3/4"	1"	1 1/4"
Weight	approx. kg	2.7	3.2	3.6
Dimensions	mm			
	H	324	324	324
	h	285	285	285
	T	150	150	150
	t	66	66	66
	r	27	27	31
	D	105	105	105
	l	90	100	105
L	162	184	203	
Flow value at $\Delta p = 0.2$ bar	m ³ /h	3.5	4.0	4.5
K _{VS} -value		5.5	6.0	6.5
DIN/DVGW Approval No.		NW-9301 BO 0224		

Method of Operation

The filter insert comprises an upper part and a lower combination section. When in the „filtering“ position, the small upper filter is closed so that the water can only pass through the main filter from outside to inside. When the ball valve is opened for reverse rinsing, the filter is pushed downwards until the water supply to the outer side of the main filter is stopped. Simultaneously, the water flow is opened to the upper part of the filter. The water needed for cleaning the filter passes through the upper sieve, the rotating impeller and the main filter from inside to outside. By this means, the filter is fully cleaned over its whole surface area at the full inlet pressure. The filter automatically switches over to the operating position when the ball valve is closed again.

Options

- F74C-...AA = Filter mesh size 100 µm, incl. rotatable connector piece DA74C with threaded male connections
 - F74C-...AC = Filter mesh size 50 µm, incl. rotatable connector piece DA74C with threaded male connections
 - F74C-...AD = Filter mesh size 200 µm, incl. rotatable connector piece DA74C with threaded male connections
- └── Connection size
- FN74C-1A = Filter mesh size 100 µm; rotatable connector piece DA74C has to be ordered separately - see accessories
 - FN74C-1C = Filter mesh size 50 µm; rotatable connector piece DA74C has to be ordered separately - see accessories

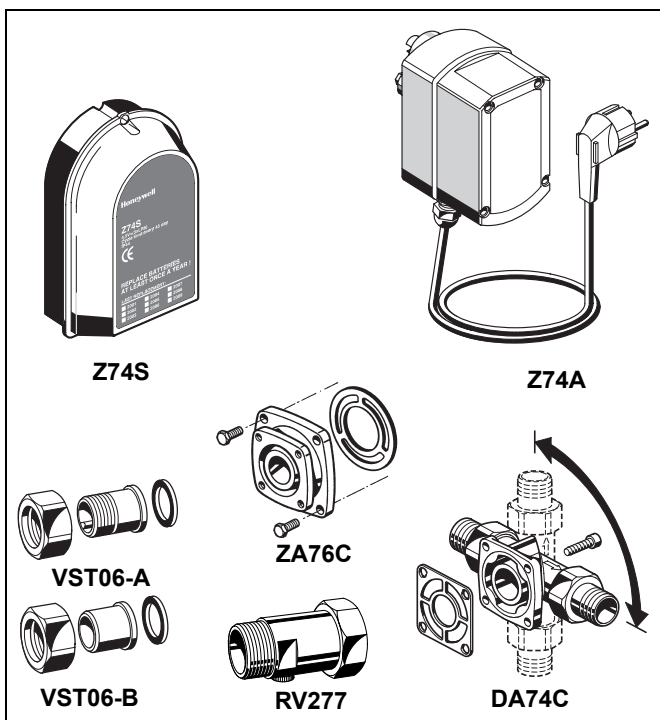

Accessories

- Z74S Automatic reverse rinsing actuator**
For automatic filter cleaning at presettable intervals
- Z74A Automatic reverse rinsing actuator**
For automatic filter cleaning at presettable intervals
- DA74C Rotatable connector piece**
For connection of retrofit filters and filter combinations
- VST06-B Connection set**
Solder connections
- VST06-A Connection set**
Threaded connections
- RV277 Inlet check valve**
Available in sizes R1/2" - 2"
- ZA76C Connector piece**
For conversion of the fine filters with rotatable connector pieces (1 1/4" and 1 1/2") into retrofit filter combinations (Converts 63 mm hole centres to 45 mm hole centres)

Installation Example

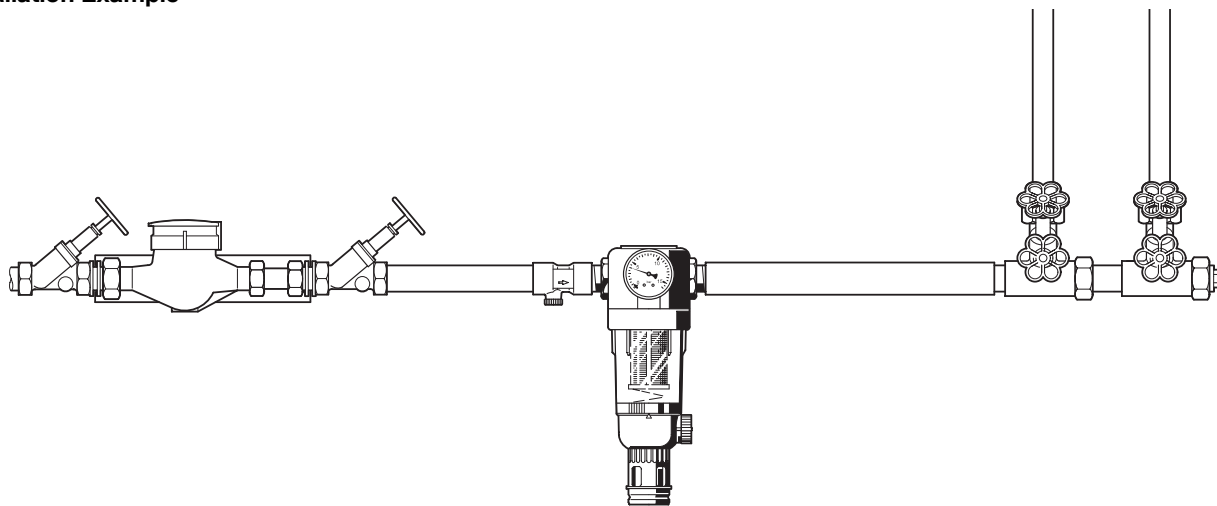

Installation Guidelines

- Install in horizontal or vertical pipework with filter bowl downwards
 - This position ensures optimum filter efficiency
- Install shutoff valves
 - Pressure gauge can be read off easily
 - Degree of contamination can be seen with clear filter bowl
 - Simplifies maintenance and inspection
- The installation location should be protected against frost
- Fit immediately after water meter
 - Corresponds to DIN 1988, Part 2

Typical Applications

Fine filters of this type are suitable for supplies to buildings of all types. They can also be used for commercial and industrial applications within the limits of their specifications.

Fine filters of this type are installed:

- Where there is existing metal or plastics pipework
- If the downstream system includes appliances which must be protected against dirt
- For installation in horizontal or vertical pipework
- As replacement for an existing filter
- Where space is limited

Flow Diagram

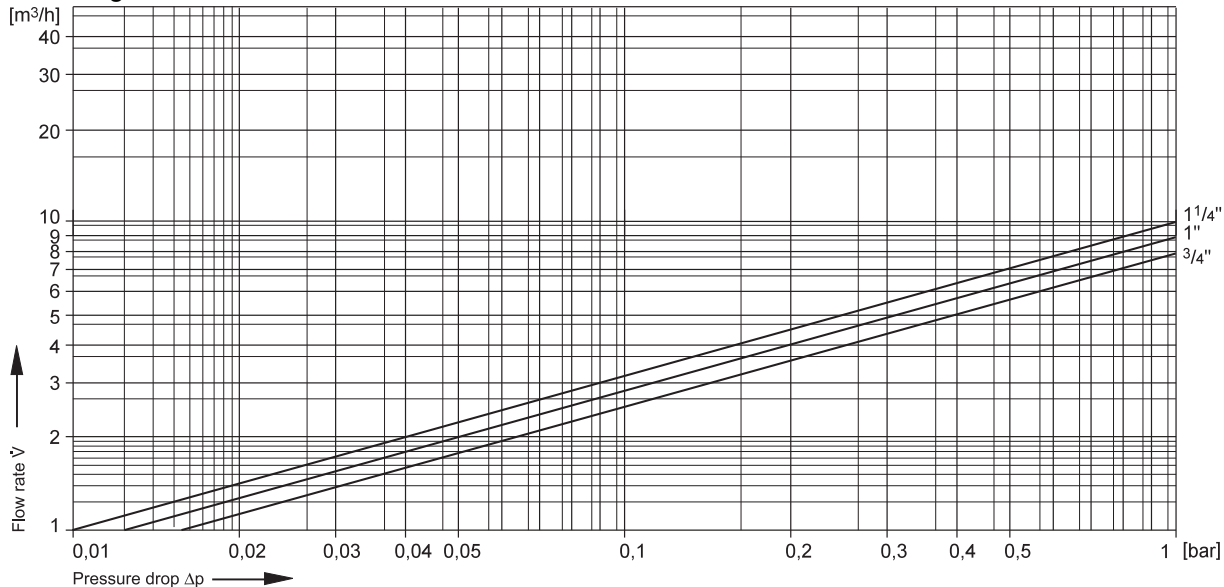

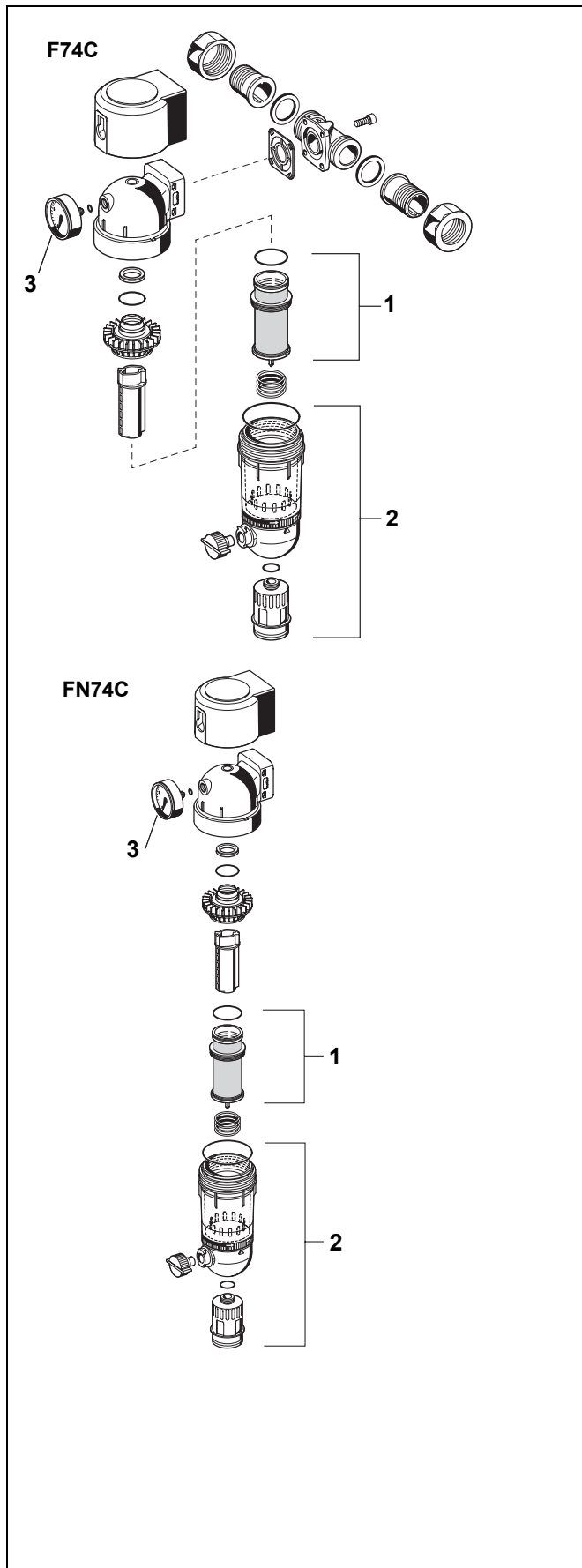

Spare Parts

F74C/FN74C Fine Filters (From 1995 onwards)

No.	Description	Dimension	Part No.
1	Filter insert complete		
	Filter mesh 100 µm	3/4" - 1 1/4"	AF74-1A
	Filter mesh 50 µm	3/4" - 1 1/4"	AF74-1C
	Filter mesh 200 µm	3/4" - 1 1/4"	AF74-1D
2	Clear filter bowl complete	3/4" - 1 1/4"	KF74-1A
3	Pressure gauge (0 - 16 bar)		M07M-A16
4	Double ring wrench for removing filter bowl (no fig.)	3/4" - 1 1/4"	ZR10K-3/4

Automation and Control Solutions

Honeywell GmbH
 Hardhofweg
 D-74821 Mosbach
 Phone: (49) 6261 810
 Fax: (49) 6261 81309
<http://europe.hbc.honeywell.com>
www.honeywell.com

Manufactured for and on behalf of the
 Environmental and Combustion Controls Division
 of Honeywell Technologies Sàrl, Z.A. La Pièce 16,
 1180 Rolle, Switzerland by its Authorised Representative Honeywell GmbH

EN0H-1148GE23 R0210
 Subject to change without notice
 © 2010 Honeywell GmbH

Honeywell